

## Dual 1x2MEMS Switch(Module)

### RD-MS-Dual-1×2-PM-M-780-90-10-FA-TTL

## PM(Polarization-maintaining) Dual 1X2 MEMS Optical Swith,PM PM780 , 0.9mm loose tube Fiber, FC/APC,TTL Control connection, 90x55x12mm

RD-MS-Dual-1×2-PM-M-780-90-10-FA-TTL PM Dual 1×2 MEMS Optical Switch is a high-performance polarization-maintaining fiber optical switch based on Micro-Electro-Mechanical Systems (MEMS) technology. It is specifically designed for fiber optic communication and sensing applications requiring strict polarization state maintenance. Featuring an advanced micro-mirror drive architecture, it offers ultra-low insertion loss, high extinction ratio, fast switching speed, and exceptional reliability. It is widely used in fiber optic sensing systems, precision optical measurement, laser scanning microscopy, Fiber Bragg Grating (FBG) monitoring, polarization-sensitive optical path switching, and other demanding applications.

## Applications

- ◆ **Fiber Optic Sensing Systems:** Optical path switching and monitoring for FBG fiber grating sensor networks
- ◆ **Precision Optical Measurement:** Polarization-sensitive optical testing and metrology equipment
- ◆ **Laser Scanning Microscopy:** Fast routing and switching of multi-channel laser sources
- ◆ **Optical Communication Networks:** Optical line protection, OADM, and ROADM applications
- ◆ **Spectral Analysis:** Optical path selection and signal distribution for multi-channel spectrometers
- ◆ **Quantum Optics Experiments:** Precise control and switching of polarization-maintaining optical paths

## Environmental Conditions

Parameters	Unit	Min	Max
Storage Temperature	°C	-40	85
Operating Relative Humidity	%RH	5	95
Operating Temperature	°C	-5	70

ESD Level (HBM)	V	500	
Max Power Handling	mw		500

## Optical Specifications

Parameters	Unit	Specification
Channels	CH	Dual 1x2
Testing Wavelength	nm	780
Insertion Loss	dB	≤2.0 (with connector)
Return Loss	dB	≥50
extinction ratio	dB	≥16dB
Repeatability	dB	0.03dB Max
Crosstalk	dB	≥50
PDL	dB	≤0.15
TDL	dB	≤0.3
Response Time	ms	≤20
Durability	Cycle	≥1×10 <sup>9</sup>
Drive Voltage (Max)	V	5~12
Control Type	TTL(Parallel /Serial Port Compatibility) The two switches are controlled on the same channel	

### Notes:

1. The loss is based on the test results at 23°C.
2. Repeatability is defined after 100 cycles.

## Electronic Requirement

### Pin Definition:

Pin number	Pin Assignment	Signal Type	Description
1	D0	Input	Data bit (D0) (low-order)
2	D5	Input	Data bit (D5)
3	VCC	Power	Power Supply (DC 5V,1.0A)
4	D7	Input	Data bit (D7) (high-order)
5	D6	Input	Data bit (D6)
6	GND	Power	GND
7	D4	Input	Data bit (D4)
8	D1	Input	Data bit (D1)
9	TXD	Output	Data Transmit (TTL Level)

10	RXD	Input	Data Receive (TTL Level)
11	D2	Input	Data bit (D2)
12	D3	Input	Data bit (D3)
13	/BUSY	Output	Low level means ready to reset or receiving data
14	/ALARM	Output	High level means running error
15	/STROBE	Input	Falling edge execution data bit
16	/RESET	Input	Low level reset to channel 0

Note: Molex 87833-1620 is used for the electrical interfaces of this modules and it is recommended to use Molex 87568-1694 for customer connectors.

## UART program control instruction description

This module can receive control signals through the UART interface to enable automated measurements or real-time monitoring.

- (1). This module can only execute one instruction at a time. Typically, the next instruction can be entered only after the program returns the corresponding value.
- (2) Please use capital letters.
- (3) In practical operation, the angle brackets "<" and ">" are used as the start and end delimiters respectively.
- (4). Instruction error returns <ER>.

## Program Control Instruction Set

Order	Describe	Example
<RESET>	Restart module	Successful return: <RESET_OK>
<RESTORE>	Reset	Successful return: <RESET_OK>
<INFO_?>	Query module information	Return successfully: <MEMS-Dual-1X8_VER1.00_ SN01234567890_08.04.00051> Indicates MEMS-Dual-1X18 module, version 1.00, SN number 01234567890, product number 08.04.00051;
<BAUD_x>	Set or query the serial port baud rate 1.x is 1~9, indicating baud rate 2400, 4800, 9600, 14400, 19200, 38400, 56000, 57600, 115200 respectively Successful return: <BAUD_x_OK> 2. Send <BAUD_?> to query the baud rate	Send: <BAUD_5> Successful return: <BAUD_5_OK> Set the device serial port baud rate to 19200  The configuration will take effect

		after saving and rebooting!
<OSW_M_x>	Working mode selection x: Values 0, 1, ?, 0 indicates data bit control switching, 1 indicates UART control switching, ? indicates query working mode; Successful return: <OSW_M_x_OK>	Send: <OSW_M_1> Successful return: <OSW_M_1_OK> Indicates that the module is set to UART control switching;  Send: <OSW_M_?> Successful return: <OSW_M_1> Indicates that the module is UART controlled switching;
<OSW_01_SW_xxx>	Set current channel xxx: The value is 000~256, 000 means 0 channel, 256 means 256 channel; Successful return: <OSW_01_SW_xxx_OK>  Note: In data bit control switching mode, Send: <OSW_01_SW_xxx> Return: <OSW_M_ER>	Send: <OSW_01_SW_002> Successful return: <OSW_01_SW_002_OK> Indicates switching to channel 2;
<OSW_A_?>	Query channel status Successful return: <OSW_A_Optical switch channel>	Return: <OSW_A_001> Indicates that the optical switch is 1 channel;
<SAVE_ALL>	Save configuration Successful return: <SAVE_ALL_OK>	Save the configuration, such as saving the channel status.

### Data bit switching logic table

/RESET	D7	D6	D5	D4	D2	D1	D0	Channel
0	X	X	X	X	X	X	X	0
1	0	0	0	0	0	0	0	1
	0	0	0	0	0	0	1	2
	0	0	0	0	0	1	0	3
	...	...	...	...	...	...	...	...
	0	0	0	1	1	1	1	24

### Factory default configuration

Project	Factory Default Configuration	Remark
Serial port baud rate	115200	8 data bits, 1 stop bit, no parity.
Operating mode	UART control switching	
Working channel	When UART control is switched, the working channel is channel 1; When data bit control switches, the working channel is determined by the data bit;	When switching the UART control, the module preserves the optical path state that was saved during configuration even after power is disconnected and reconnected.

PCBA: D3-1 V56

### Mechanical Requirement

(Units: mm)

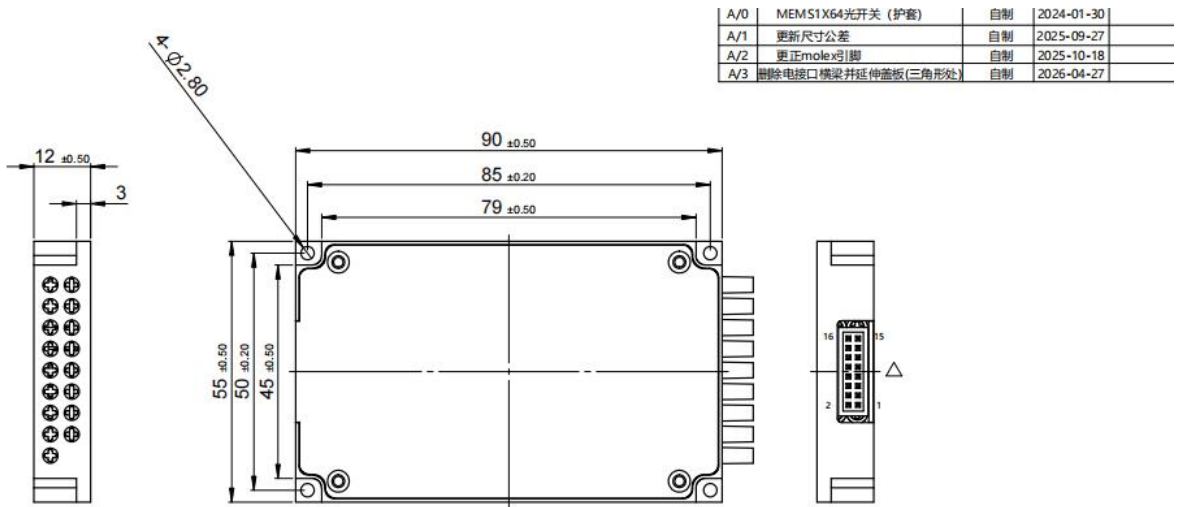

### Pigtail/Connector Requirement

Parameters	Specification
Fiber Type	PM780, 0.9mm loose tube
Fiber Length/Tolerance	1+/-0.05m (without connector)
Connector	FC/APC

Channel mark	White number tube with black font, Input--COM1,COM2 Output-- OUT1-1,OUT1-2,OUT2-1,OUT2-2
--------------	--